



04 74 07 13 11 Groupe TOTEM



BUREAU VERITAS

Protection des piétons

ClassiFLEX™ - SINGLE TRAFFIC

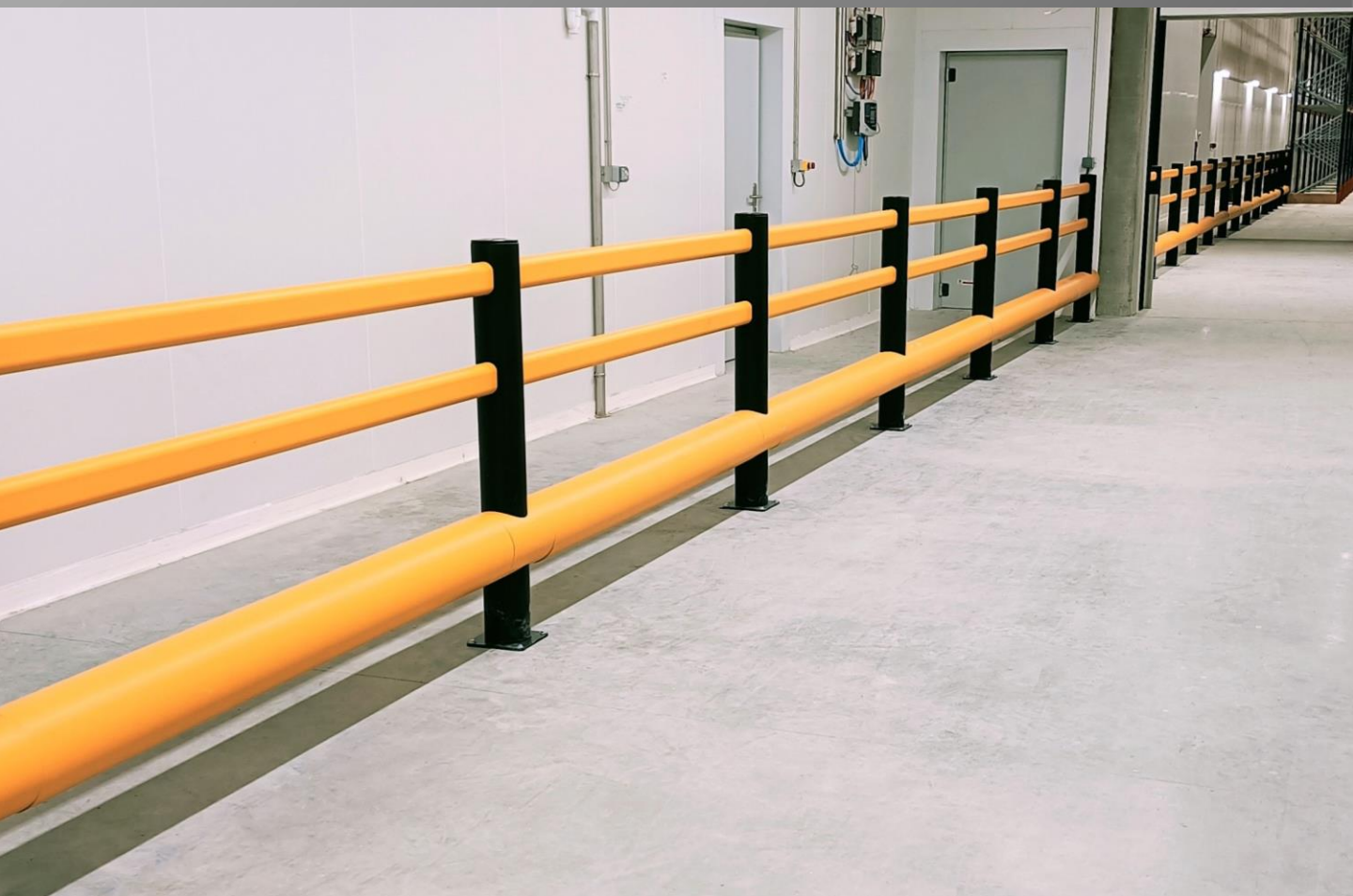

CONÇUES ET FABRIQUÉES EN FRANCE



Protection des piétons

ClassiFLEX™ - SINGLE TRAFFIC



Barrière piétonne renforcée par une lisse basse de gros diamètre pour les impacts provoqués par la gueuse d'un engin de manutention.

Permet la séparation entre les zones piétons et les zones où manoeuvrent les chariots élévateurs.

 RAL 1007

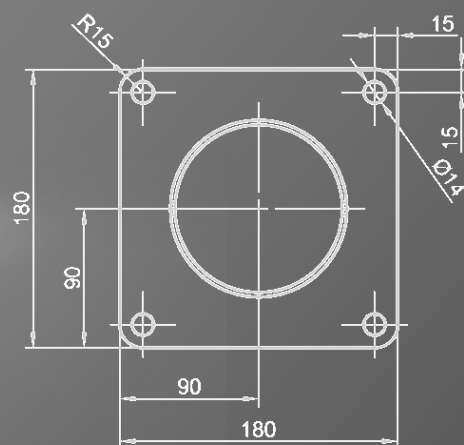
 RAL 9005

Caractéristiques techniques

Matière	Polyeix - matière à mémoire de forme + métal traité cataphorèse pour les platines
Nombre de lisses	2 piétonnes + 1 butée
Section lisses	2 lisses oblongues section 90 x 50 mm + 1 lisse basse Ø 195 mm
Hauteur sur lisse	H. 1100 mm sur lisse supérieure H. sur lisse basse 400 mm
Diamètre poteaux	Ø 130 mm
Dimensions platines	180 x 180 x 8 mm
Fixation	Chevilles mécaniques à expansion Ø 12 mm

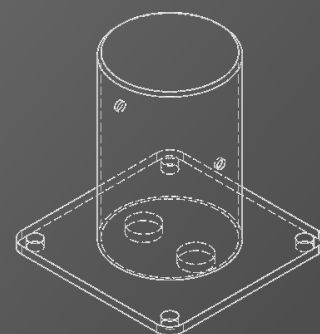

Options

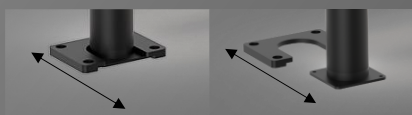

Amovible



FABRICANT & ARCHITECTE
DE VOTRE SÉCURITÉ

Groupe
TOTEM



98 rue de l'Ancienne Distillerie
ZAC des Grillons
69400 Gleizé - France

Tél. : 04 74 07 13 11

Mail : contact@protect-choc.fr



N° SIRET : 518 673 421 00021 - code APE : 2229A